

Corporate Presentation Group Companies



Group Companies

COSMO GROUP

COSMO FILMS
Engineered to Enhance

COSMO FERRITES LIMITED



Backward Integration in chemicals, masterbatches and adhesives.



An all in one solution to all pet products, Accessories and services.

FILMS BUSINESS

A global leader in speciality films for packaging, labeling, lamination and synthetic paper applications.



Leading manufacturer and exporter of Mn-Zn Based Soft Ferrite Cores for Power Electronic Industries.



Manufacturer of Coils and Transformers

COSMO FILMS LTD



Establishment

Established in 1981, Cosmo Films Limited is one of the largest BOPP film players in the world with a sales turnover of USD 311 Million in FY 2018-19.



World Leader in Thermal Lam Films

Cosmo Films is the world's largest producer of thermal lamination films.



Certifications

ISO 9001:2000
ISO 14001:2004
British Retail Consortium (BRC)
American Institute of Baking (AIB).



Strong Export Footprints

Leading BOPP Films exporter from India with export to more than 100 countries.



Promoter

Promoted by Mr. Ashok Jaipuria, 1st generation entrepreneur, who introduced the country to BOPP Films.



Public Listed

The company is listed on the Bombay Stock Exchange (BSE) & National Stock Exchange (NSE), India.



Awards & Recognition

Winner of several awards for innovation viz. PFFCA, Asia Star, SIES, SAP Hana, SAP Visionary etc.



Strong R&D Focus

Collective R&D experience of over 30 years
Recently received one patent for Release BOPP Film, holds 6 patents in India and 3 in the US
Have a state of the art R&D centre in Aurangabad.

MANUFACTURING FOOTPRINT



Waluj, Aurangabad, India

BOPP- 5 lines
Thermal- 2 lines
Coating -3 lines
Metalizing- 1 line
CPP- 1 line



Shendra, Aurangabad, India

BOPP- 1 line
Thermal- 4 lines
Coating- 2 lines
Metalizing- 1 line



Karjan, Vadodara,
India

BOPP- 3 lines
Coating - 1 line
Metalizing - 2 lines
CPP - 1 line
CSP - 1 line



Asan, Korea
Thermal- 1 line



TOTAL INSTALLED CAPACITY

BOPP -2,00,000 TPA (9 lines)
Thermal- 40,000 TPA (7 lines)
Coating- 16,000 TPA (6 lines)
Metalizing - 20,000 TPA (4 lines)
CPP- 9,000 TPA (2 lines)
CSP- 7,200 TPA (1 line)

* Shrink film production planned in 2022

**BOPET line to be commissioned by 2022

COSMO SPECIALITY CHEMICALS

A 100% Subsidiary of Cosmo Films



COSMO SPECIALITY CHEMICALS

A 100% Subsidiary of Cosmo Films

Brand Purpose

To enrich lives with chemistry, responsibly.



Vision

“To be a preferred specialty chemicals company, constantly innovating for a better & safer tomorrow”.



Mission Statement

To provide eco-friendly consumer centric products that bring in enhanced functionalities and aesthetics.

COSMO SPECIALITY CHEMICALS

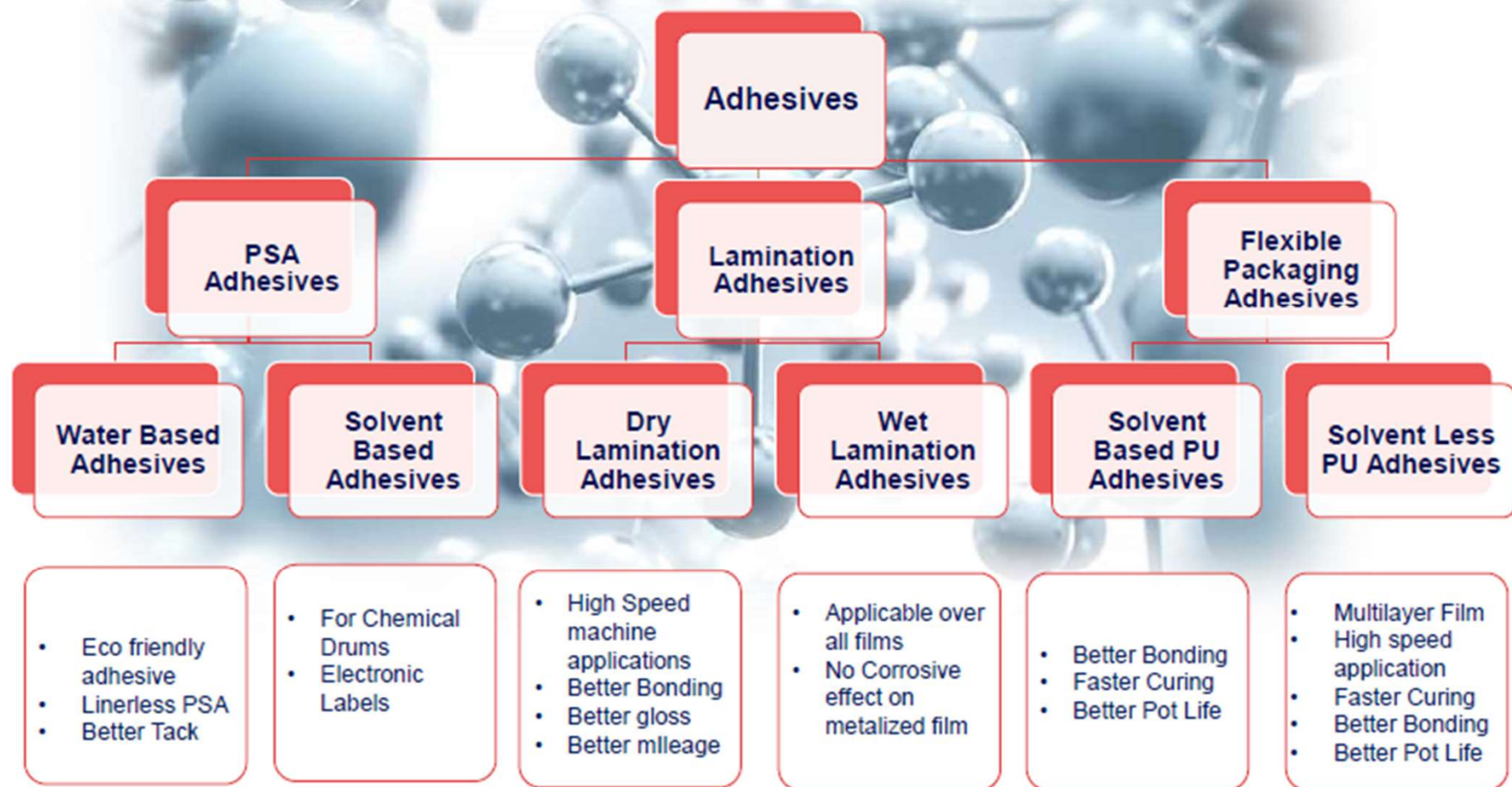

COSMO SPECIALITY CHEMICALS



Masterbatches

White
Masterbatch

Anti-blocking
Masterbatch

Slip
Masterbatch

Antistatic
Masterbatch

Cavitating and
Pearl
Masterbatch

Matt
Compound

COSMO SPECIALITY CHEMICALS

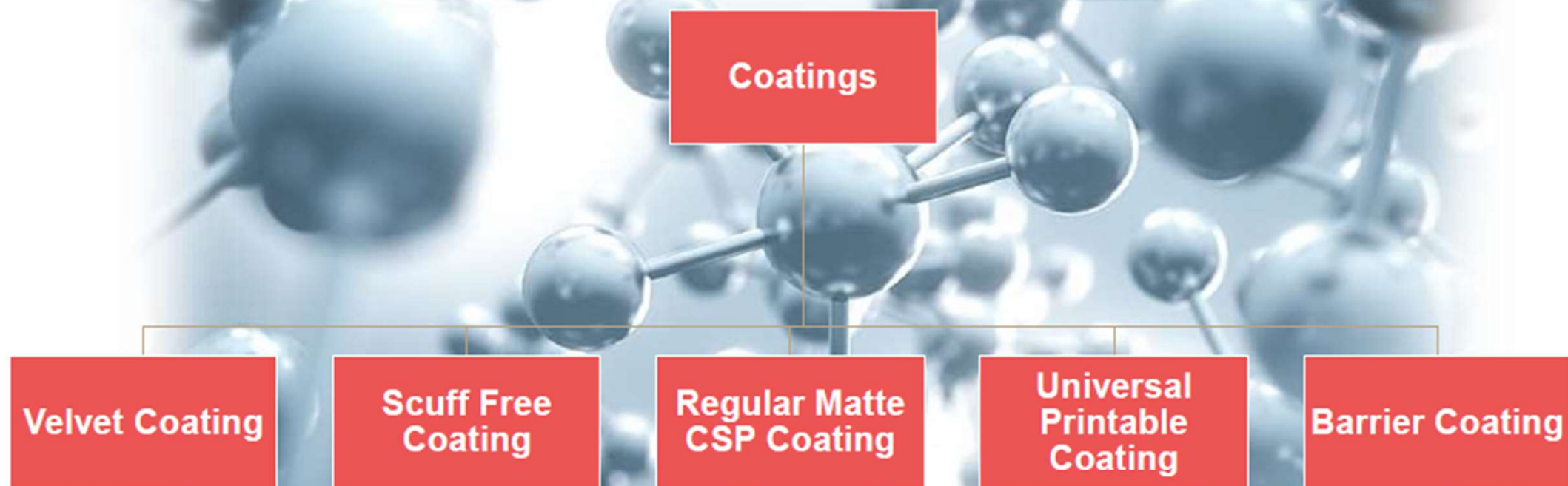

COSMO SPECIALITY CHEMICALS

A 100% Subsidiary of Cosmo Films



Adhesives
800 T/Month by 2025-26

B2C

B2B

PVA Wood adhesives



- High bond strength and Quick setting and long term bond.
- Termite and humidity resistant.

Acrylic Construction adhesives



- Admixture for cements better binding and water resistance.
- Water proofing polymer additive.
- Alternative for mechanical fasteners and rivets.
- Excellent for joining dissimilar substrates

Acrylic PSA



- Environmental friendly durable adhesives.
- Clear removable.
- Linerless PSA.

PVA Lamination

- High speed applications.
- Very good green bond.

Epoxy for flooring & Metal bonding



- Formulations for Low temp curing one component system
- User friendly application



ZIGLY

For Happy Pets

Brand Purpose

Happy Pets- Our Purpose is to give happy and healthy lives to the furry companions who makes our lives whole.



Vision 2025

“To build India’s largest Pet care ecosystem connecting Pet families with compassionate reliable and competent caregivers”.



Mission Statement

Pet families To provide easy access to reliable, standardized and quality pet care that enhances the joy of pet parenting.

Care Givers To provide steady and equitable income opportunities to pet lovers who chose to transform their passion in to profession.

BRAND ARCHITECTURE



OUR INITIATIVES AND ACHIEVEMENTS



Infrastructure

- ❖ R&D labs with most sophisticated equipment and instruments, one in India & another one in USA.

Some of the equipment & instruments

- Barrier Testing (OTR & MVTR).
- Differential Scanning Calorimetry (DSC)
- Thermo Gravimetric Analysis (TGA)
- Dynamic Mechanical Analyzer
- Mass Spectrometer (MS).
- Optical Microscope.
- Dynamic Mechanical Analyzer.
- FTIR – Microscope
- Scanning Electron Microscope (SEM).
- UV spot coating and screen printing.
- ANSI Barcode scanner.
- UV Flex proof 100.



Achievements

- ❖ Recognition and certification by Department of Scientific & Industrial Research, Government of India.
- ❖ Recently received one patent for Release BOPP Film.
- ❖ Multiple patents with 6 in India and 3 in the US.
- ❖ Multiple product development Awards such as India star, IFCA STAR and PFFCA STAR awards.
- ❖ First thermal lamination film to take extrusion coating without the primer. -

SUSTAINABLE PRODUCT PRACTICES

Offer mono-material poly-olefin films for ease of recycling.

Designed heat resistant BOPP films replacing BOPET; mostly used in print layer, giving last push to creation of mono-material structures.

Company has been partnering with some of the best global brands to offer structure rationalization.

Both BOPP and CPP films offer better yield, hence enabling reduced consumption of plastics.

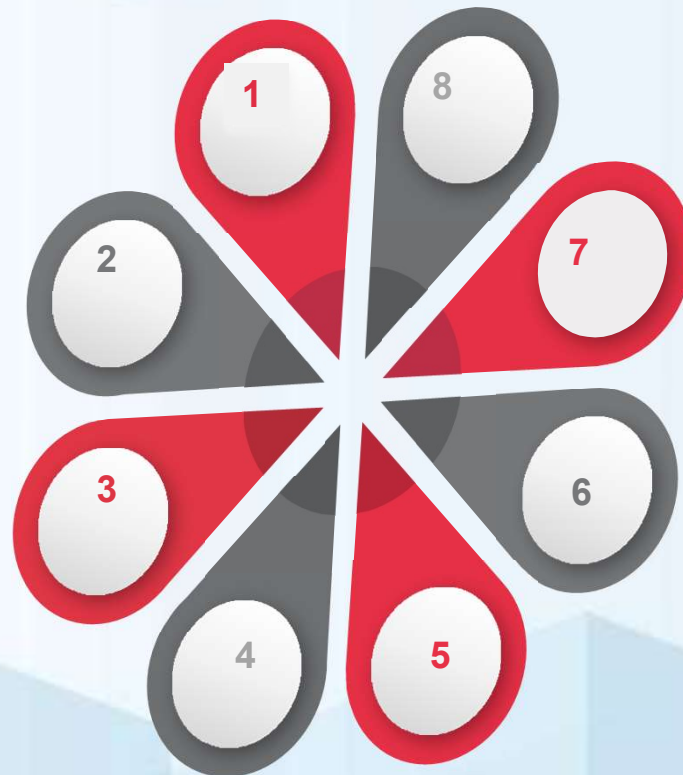

UV stabilized Synthetic Paper can be used to replace PVC in outdoor promotional applications for shorter duration requirements up to one year.

Use of Water Based Coatings.

Offer Oxo-Biodegradable Films.

Offer a suitable substitute for aluminum foil in form of its Ultra-High Barrier Films.

PILLARS OF COSMO FOUNDATION (SOCIAL RESPONSIBILITY)

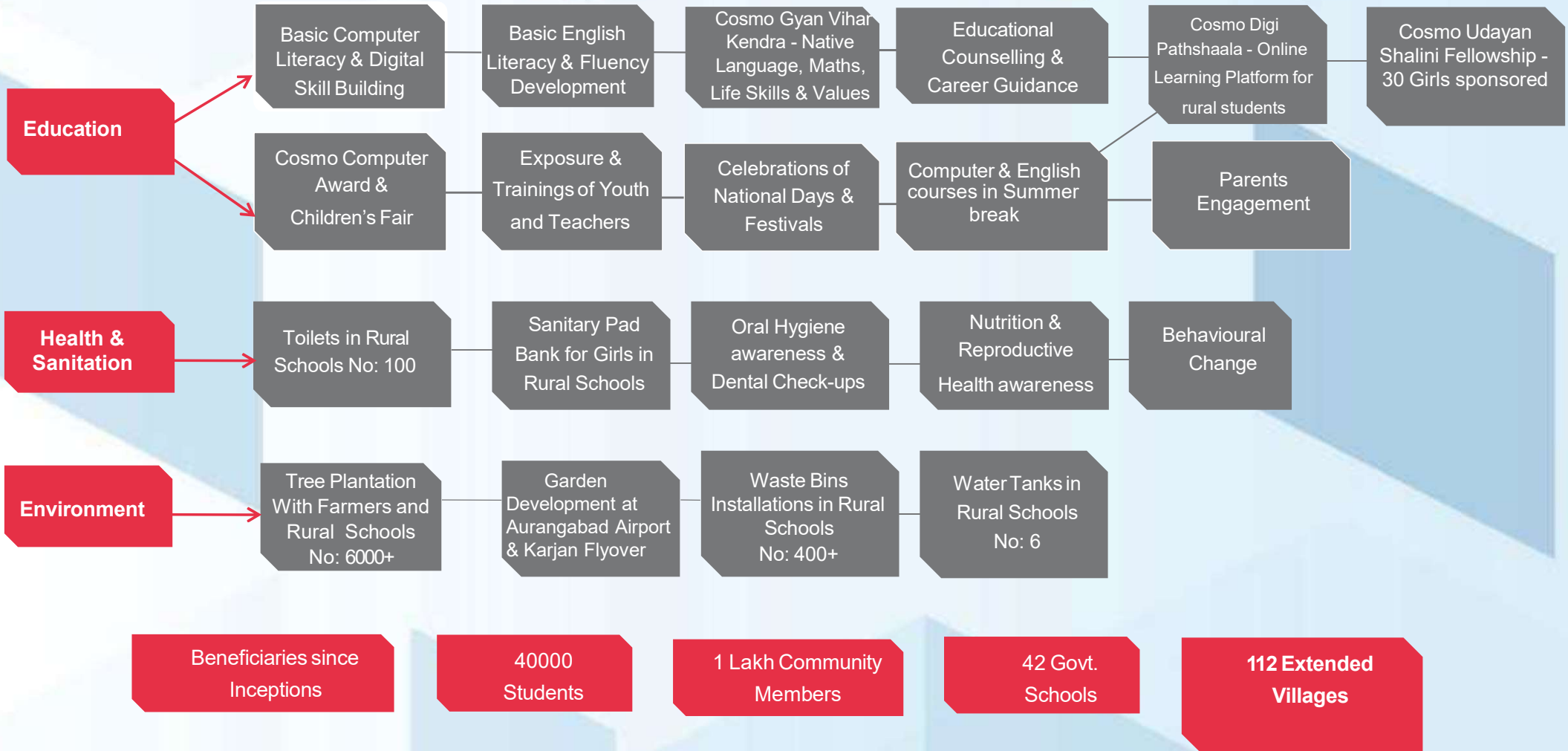

CORPORATE GOVERNANCE

Well established practices in place

1. Well qualified Board of Directors from diversified fields
2. with majority of directors being independent.
3. Independent Audit Committee with Board of Directors.
4. Established risk management practices.
5. Experienced and independent internal audit function.
6. Active Whistle Blower Policy.





COSMO FERRITES LIMITED

A LEADING MANUFACTURER OF SOFT FERRITE CORES

COSMO FERRITES LTD.



Background

Established in 1986. Cosmo Ferrites Limited is one of the largest soft ferrite manufacturer in India

Capabilities

Soft Ferrites (Mn Zn) capacity 80Mn Pc/ Month
In house Ferrite Powder capacity 3600 MT.

Accreditations

ISO 9001:2015
ISO 14001:2015
ISO/TS 16949
UL94 V-0

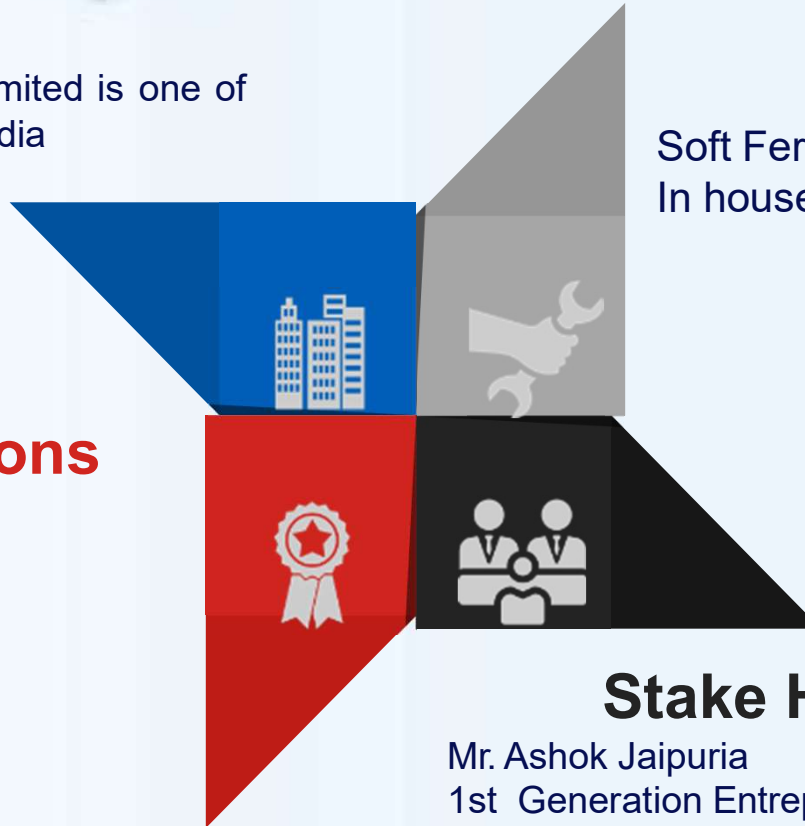

Stake Holders

Mr. Ashok Jaipuria
1st Generation Entrepreneur, introduced the country to Soft Ferrite Cores.

Mr. Ambrish Jaipuria
Managing Director at Cosmo Ferrites Ltd.

Who We Are



Manufacturing Plant

Located in the foothills of
Himalaya.
Area 20600 sq m.

PUBLIC LISTED

Listed on the Bombay Stock
Exchange (BSE)

EMPLOYEES

720+ employees

VISION

To become the Product and Quality
leader of soft ferrite cores.

MISSION

We endeavour to be an organization
which delivers outstanding
customer service, respects all
individuals working with it and
always encourages initiative &
innovation

VALUES

Conduct business with integrity
and fairness.
Focus on our customer's need.
Excellence in quality & customer
service.
Mutual respect and teamwork.

Cosmo Ferrites Journey So Far

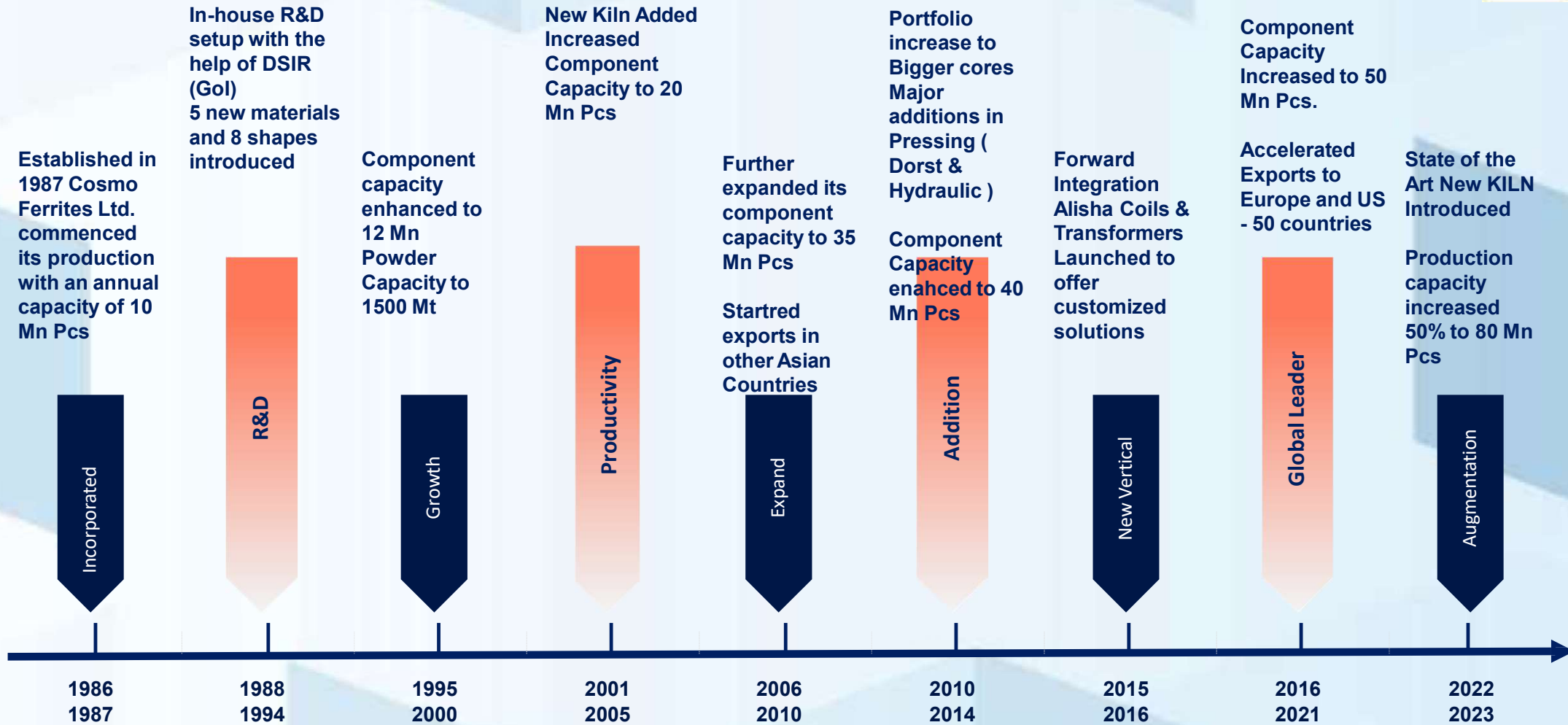

Leadership Team



Mr. Ambrish Jaipuria
Chairman



Mr. Pankaj Poddar
Group CEO



Mr. Supratic Roy
Business Head



Mr. Sanjeev Katoch
General Manager



Mr. Rishab Jain
Chief Financial Officer



Mr. K Sriram
AGM (Operations and R&D)

Professional Team



Mr. Ramesh Chaudhary
AGM (SMC, IT & Costing)



Mr. P K Jain
Sr. Manager (Domestic Marketing)



Mr. Pradeep Sharma
Manager (Export Marketing)



Mr. Ravi Luthra
Manager HR



Mr. Rajesh Kumar
Manager Purchase



Mr. Satya PVV
Business Head ACT

Awards Recognized by ELCINA for continuous growth and development.



ELCINA-EFY Certificate of Merit for Outstanding Achievement in "Exports/Large Scale" Year 2016-17



ELCINA-EFY Certificate of Merit for Outstanding Achievement in "Exports/Large Scale" Year 2013-14



ELCINA-EFY Certificate of Merit for Outstanding Achievement in "Exports" Year 2020-21



43rd ELCINA-EFY Award for Outstanding Achievement in "Exports/Large Scale" Year 2017-18

Our Customers - Domestic





Our Customers - Domestic

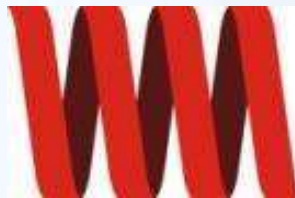
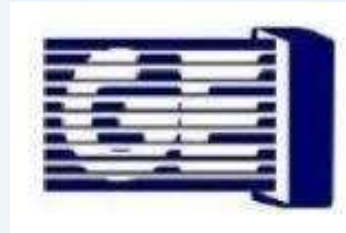

Our Customers - Export





Company Presence Global



1

64 % - Asia

India | China | Sri Lanka
Thailand | Taiwan
Malaysia | Vietnam | Japan

2

28 % - Europe

Germany | Italy | Poland
Czech Republic | Spain
United Kingdom | France
Ukraine | Denmark

3

3 % - North America

United States of America

4

3 % - Turkey

5

1% - Others

Africa | Brazil | Latin
America | Oceania

Distributor Network



Compliance with Global Standards



IATF 16949



ISO 9001:2015
(ACT)



ISO 9001:2015
(CFR)



ISO 14001:2015



UL94 V-0 Approved
Coating

Segments We Serve - Ferrites



Automotive
Antenna, Sensors



Solar
Inverter, Current Sensor



Industrial Electronics
Medical, Power Supplies



Electric Vehicle
Battery Charger, OBD, Wireless Charging



EMI Filters
Line Filter, Choke



Lighting
Inductor, Transformer



Segments We Serve - Wound Components

E-Vehicle



- DC-DC Converter
- AC-DC Converter
- Motor Controller
- Battery Charger

BLDC



- Fan Driver
- Motor Controller

LIGHTING



- Electronic ballast for energy efficient lamps
- Electronic chokes for Tubular Lamps

POWER CONDITIONING



- Medical electronics
- Telecom
- SMPS
- Induction

EMI FILTERS



- Battery Chargers
- Solar invertors
- Sensors

CHARGERS



- Mobile Charger
- Setup Box Charger
- RO Charger
- Adopters



Product Categories- Ferrites



EE Cores

- Sizes Available from 10 mm to 128 mm
- Application – Power Transformer and Inductors



Pot Cores

- Sizes Available from 14 mm to 36 mm
- Application – Power Transformers, Power Inductors, Converters, Inverters, SMPS and Filter Inductors



Toroid (With and Without Coating)

- Sizes Available from 06 mm to 202 mm
- Application - Wide Band and Pulse Transformers and Common Mode Chokes



RM Cores

- Sizes Available from 05 mm to 14 mm
- Application – Power and Wide Band Transformer; High Q Inductors and Tuned Transformers



UU Cores

- Sizes Available from 10 mm to 141 mm
- Application – Power Transformer and Inductors



EER/ETD Cores

- Sizes Available from 29 mm to 59 mm
- Application – Power Transformer and Inductors



Product Categories- Ferrites



PQ Cores

- Sizes Available from 20 mm to 71 mm
- Application – Power Transformer and Inductors



Planar Cores

- Sizes Available from 18 mm to 153 mm
- Application – Differential Inductors and DC/DC, AC/DC converters



EC Cores

- Sizes Available from 35 mm to 90 mm
- Application – Power Transformer and Inductors



I Bars, Plates

- Sizes Available from 20 mm to 186 mm
- Application – Antennas, High Frequency Welding, EV Charging.



PM Cores

- Sizes Available from 50 mm to 87 mm
- Application – Power Conversion Transformer



EFF Cores

- Sizes Available from 15 mm to 30 mm
- Application – Excellent space utilization for transformers and inductors

Product Categories- Wound Components

TRANSFORMERS

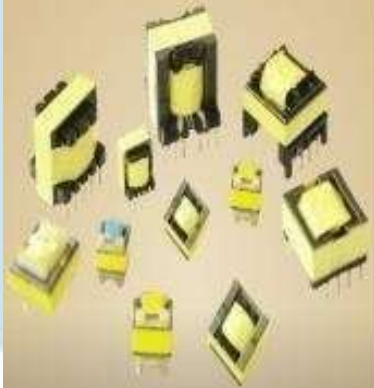

LED / CFL COILS

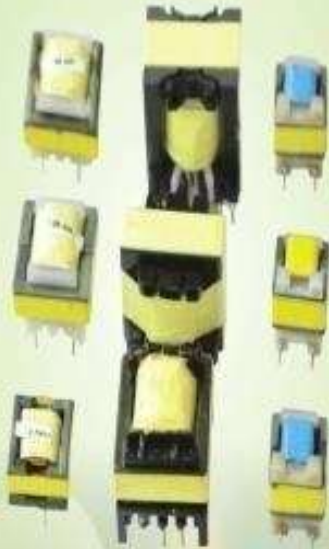

TORROIDAL COILS



EMI LINE FILTERS



**Wound Components
For All Industries**

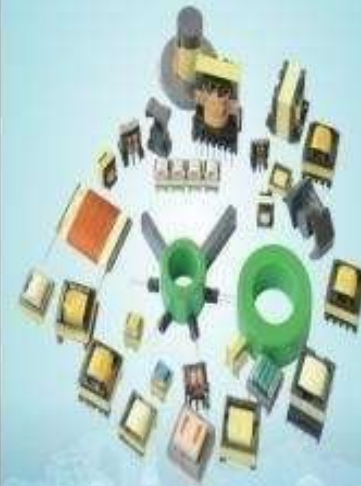



Our Approach to Sustainability

Technology



- Customized innovation
- Product Life Cycle Ahead on curve
- Wide product portfolio

Environment



- Carbon footprints reduction
- Low Emission / Zero Emission
- People health , safety and well beings

Values



- Sincerity
- Humility
- Integrity
- Passion



R&D , Quality & Technology

July 6, 2022

About Ferrites



Ferrite

(A class of advanced electro-ceramics having **magnetic** properties which contains **iron oxide** as a major ingredient)

Soft Ferrite (Inductors & transformer)



Hard Ferrite (Permanent magnet)



Mn-Zn Ferrite

- Low loss material for efficient power transmission
- High permeability material for filter application

Ni-Zn Ferrite FY24

(For EMI / EMC with high impedance)

Ferrite Material Profile



POWER GRADE MATERIAL/ LOW LOSS MATERIAL



Key properties

- Low power loss
- High magnetic flux density
- High Curie Temperature

No. of material grades available in Cosmo-09

Typical Grades- CF 292 (High B_{sat}), CF297 (low loss), CF295 (temperature stability), CF 139 (moderate power loss)

HIGH PERMEABILITY MATERIAL



Key properties

- High permeability
- Low loss factor

No. of material grades available in Cosmo-08

Typical Grades- CF 195 (μ i 5000), CF 190 (μ i 6000), CF 197(μ i 7000), CF 199 (μ i 9000)

Quality Management Principles



- **Customer-Centric Organization**
- **People involvement**
- **Process Approach**
- **Systematic Approach :- Indigenous ERP to track traceability, control and access to every stage with progress status.**
- **Continual Improvement plans and its tracking**
- **Factual Approach to Decision Making**
- **Mutually Beneficial Supplier Relationships**

Quality Tools & Techniques in Practice

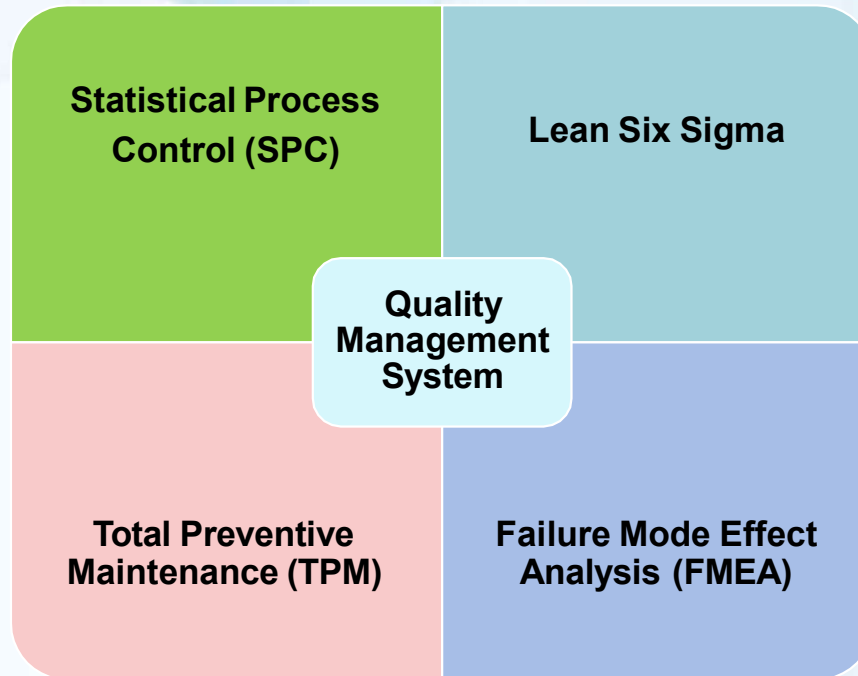

Customer complain reduced (FY 2020-21 vs 2021-22) : 30%

Reduced customer returns of total sale (FY 2020-21 vs 2021-22): 0.65% - 0.3%

Quality Compliance



- **Our products conform to IEC standard for all electrical and mechanical parameters of ferrite.**
- **Compliant with RoHS and REACH standards**

International Electrotechnical Commission (IEC)

A leading global organization head quartered at Geneva ,Switzerland that sets the International Standards for all electrical, electronics and related technologies.

Quality Gates

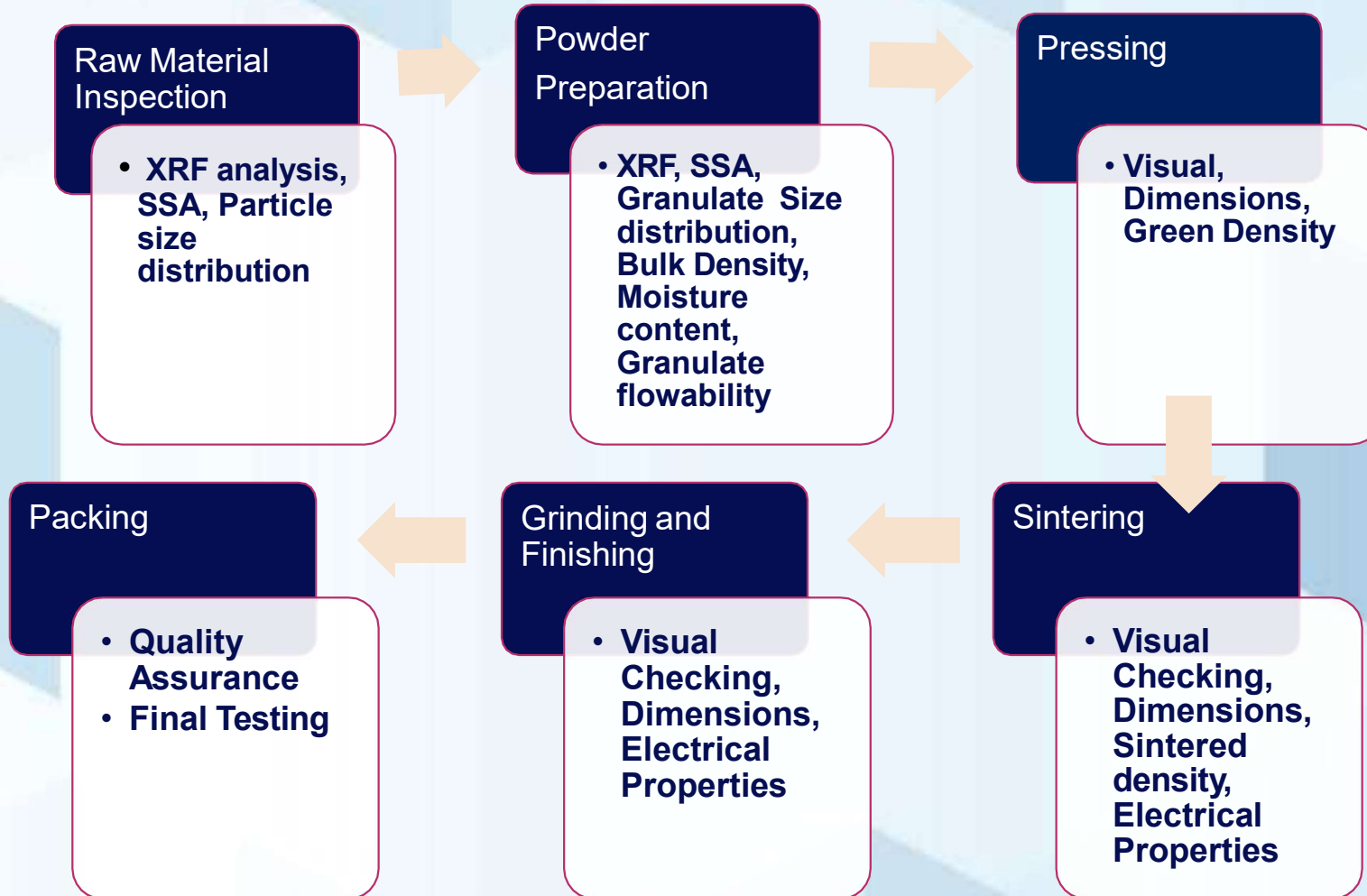

Material Development-Ongoing R&D Projects



Present portfolio

Target profile

Power
Material

Low loss at 100°C
Material Grade: CF297
Power loss : **400 kw/m³** at 100°C, 100 KHz, 200 mT

Low loss at 500 KHz
Material Grade: CF249
Power loss : **80 kw/m³** at
500 kHz, 100°C, 50 mT

Low loss at 3 MHz
Material Grade: CF250
Power loss : **800 kw/m³**
at 3 MHz, 100°C, 30 mT

Ultra low loss at 100 KHz, 200 mT
Material Grade: CF298
Power loss : **250 kw/m³** at 100°C, 100 KHz, 200 mT

Low loss at high ambient temperature (140°C)
Material Grade: 289
Power loss : **400 kw/m³** at 140°C, 100 KHz, 200 mT

High saturation
Material Grade: CF292
Saturation : **480 mT** at 25°C, 10 KHz , 1200 A/m

Ultra high saturation
Material Grade: CF293
Saturation : **600 mT** at 25°C, 10 KHz , 1200 A/m

High
Permeability
Material

Average μ_i 9000 at 10 KHz, 25°C
Material Grade: CF199

Average μ_i **10000** at 10 KHz, 25°C with improved
frequency response upto 200 KHz
Material Grade: CF199 A

July 6, 2022

R&D Roadmap(2022-2025)

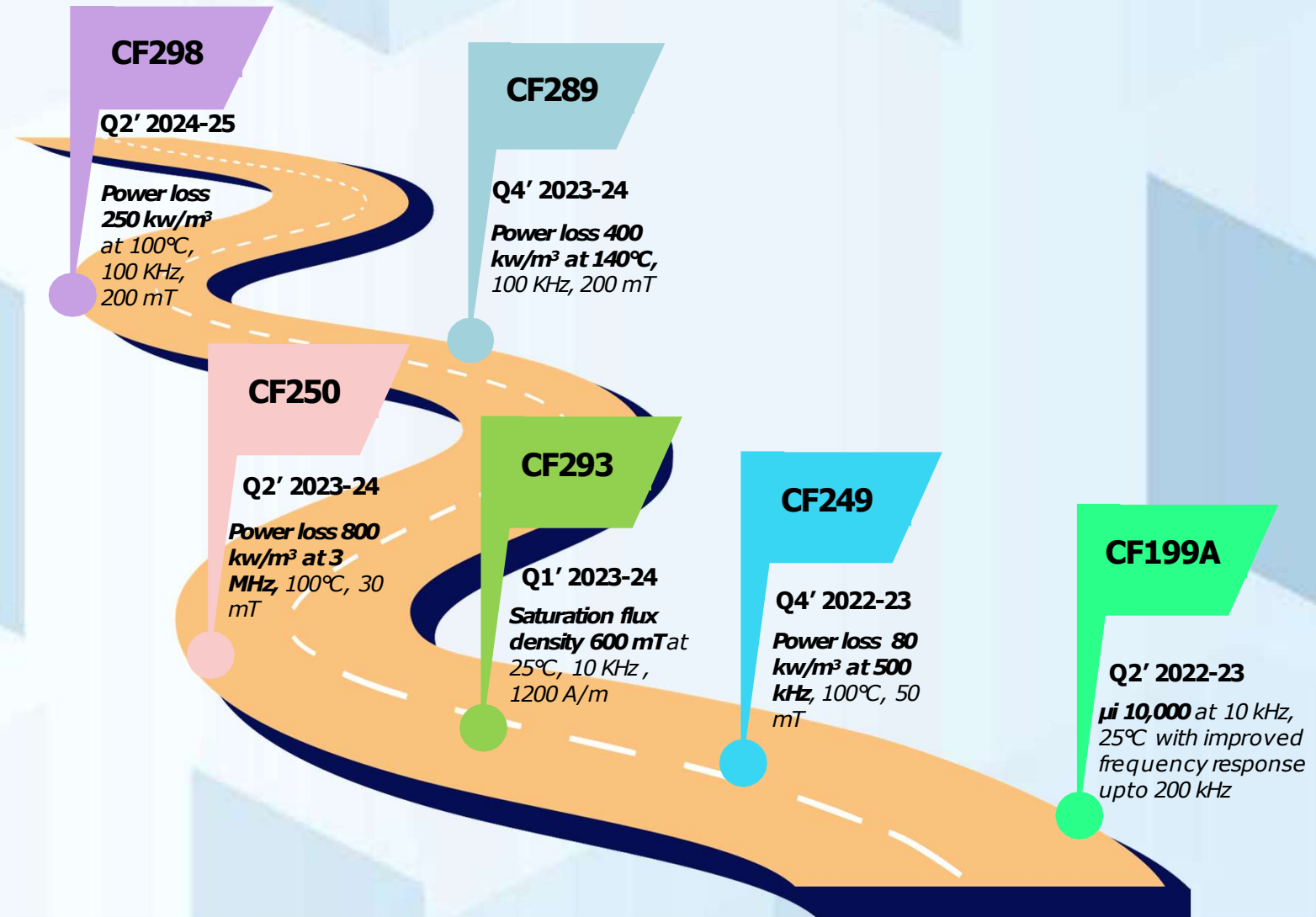

R&D Resource Center



Material characterisation & quality control



XRF for determination of material composition and purity level accurately



Particle size analyser for determination of particle size distribution in powder material



Computerised BET surface analyser for determining specific surface area of powder materials

Product synthesis and evaluation



Atmosphere controlled kiln



Powerloss set up



Transformer analyser



LCR Meter



Hi-Pot tester

Expansion of R&D Resource Center

(Planned)



Powerloss combined with B-H loop tracer capable to measure upto 3 MHz= *Planned in Q2 '2022-23*



High resolution digital microscope (1000 x) for determining granulate shape, size, defects and micro crack –*Planned in Q3'2022-23*

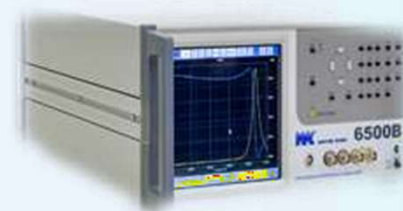

Precision Impedance analyzer capable to measure up-to 100 MHz- *Planned in Q4'2022-23*

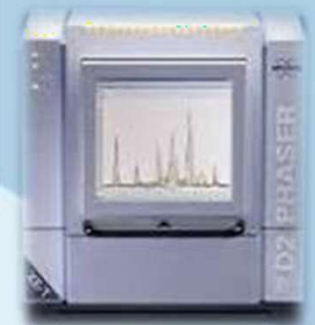

XRD for determination of crystalline phases present in ferrite system- *Planned in 2023-24*

The background features a repeating pattern of light blue and white geometric shapes, including squares and rectangles, arranged in a perspective that creates a 3D effect. The shapes are slightly offset from each other, giving the impression of a grid of blocks or a tiled surface.

Ferrite Application

Application Team



Mr. Binod Aggarwal
Expert in Power Electronics Application

M Tech in Power Electronics from IISC (Bangalore)

Mr Binod Aggarwal brings with him more than 35 years of experience in companies like **Cree, Wolfspeed.**

He's having number of patents in power electronics field like :-

Description	Patent Number
Totem pole converter system.	10224809
Hybrid analog and digital converter controller.	9606564
Boost converter with reduced switching loss and method of operating the same.	9564806
Control system for a flow cell battery.	9035617
Bi-directional buck boost circuit.	8723489
Solar power systems including control hub.	20140285023



Dr. Palas K. Haldar
Expert in Electro ceramics

M Tech , Ph. D in Material Science from University of Calcutta

Dr Palas K. Haldar has 10 papers published in various international and national journals and conferences in the field of ceramics .



Mr Karuna Sagar
New Product Development

M Tech in Material Science from Thapar University, Patiala



Mr Vikas Thakur
Application Engineer

B Tech in Electronics & Communication from HPTU, Simla.



Application

EV Charger

- **Integrated Magnetics(Inductor+ Transformer)**
Working on optimized shape of transformer and magnetic volume
Cost Effective
Better Performance
- **Distributed gap magnetics** for PFC converters and resonance inductors for LLC converters.
Better Performance at higher frequencies
- **Integrating shim inductors** along with transformer for PSFB topology
- **Integrating common mode choke and differential mode** chokes in one common magnetic structure



Shapes under consideration

- **Torroid core with a central limb. Main magnetizing inductance is controlled by the torroid and leakage can be designed with the central limb.**
- **Planar core with 2 section in the middle instead of conventional single.**
- **EE core with un-equal limb core areas and unequal limb air gaps.**
- **PQ core with double central limbs with equal or un-equal area.**

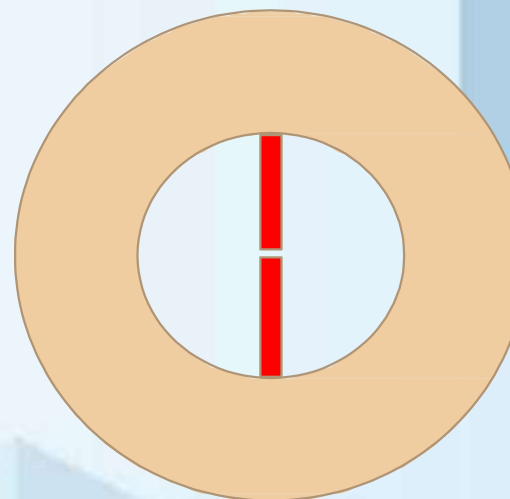

Comparison

1kW, 100kHz, $V_{in}=400V$, $V_{out}=40V$, Limb area=125mm², $L_m=250\mu H$, $L_r=51\mu H$



	Tr3 (Un-equal gap)			Tr2 (Un-equal gap)			Tr2 (Equal gap)			Separate Xformer	Separate Inductor	Total
Primary turns	72.4			73.1			65.9			27.15	36.5	
Sec turns	7.84			7.97			12			5.43	NA	
Copper loss(W)	4.48			3.97			4.53			3.08	1.98	5.06
Core loss(W)	1.59			1.6			1.81			1.63	.653	2.2
Copper weight	80.5			81.8			94			59	47.2	106.2
Core weight	76.3			76.7			87			74	36	110
Gap(Left, center, right)mm	1.7	.1	1.7	3.5	.9	.1	1.5	1.5	1.5	.68	3.9	
Flux density												

Note: comparison at 100Khz, 1KW and a max flux density of 100mT, separate transformer and inductor are on PQ core whereas for others, cylindrical 3 limb structure has been assumed.

DISTRIBUTED AIR GAP DESIGN OF THE INDUCTOR

- Fringing of the flux near air gap is increased due to air gap. Larger air gap means more fringing Fig(a) (top left).
- Fringing of the flux near the air gap causes extra eddy current losses in nearby conductors Fig(b) (top right).
- Fringing effect can be substantially reduced by providing 3 or more smaller air gaps Fig(c) (bottom).
- Fringing reduces the effective air gap of the core.
- Eddy current effect shall be more pronounced in LLC inductor and transformers compared to PFC inductor.
- One of the main dis-advantages of the ferrite core is that it saturates suddenly . This also can be reduced with distributed core.

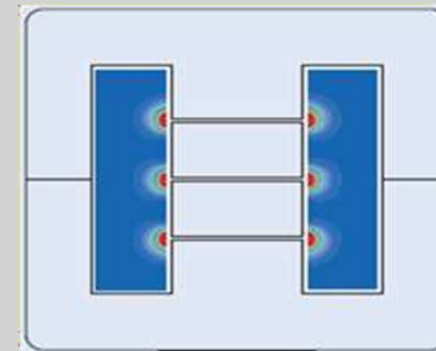
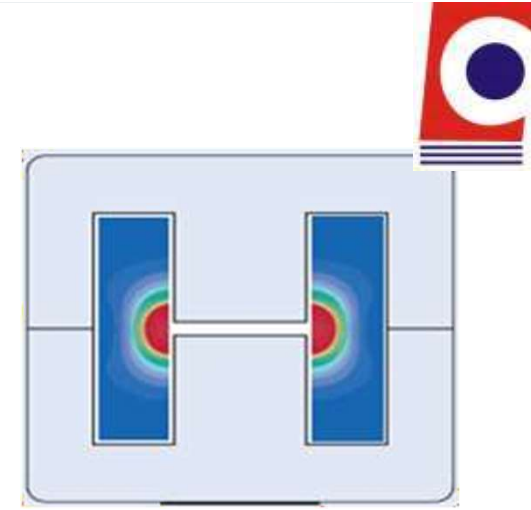
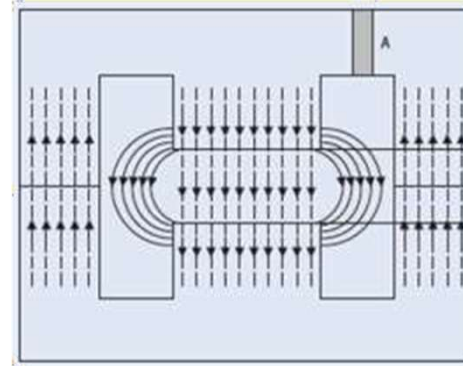

Integrating Common mode and differential mode choke.

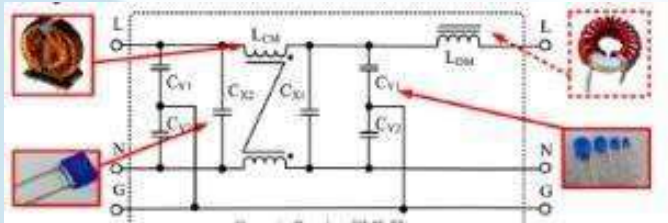

- Different configurations are possible. One possibility is with EE core.
- Other possibility is with toroid by adding another central limb.
- Differential mode inductance may be tweaked by putting extra winding on the central limb.
- Be careful about the flux in right and left limb as flux due to differential mode adds in one and subtracts in another.
- Good estimation of common mode current is needed to compute correct flux density in core.
- Need to develop a model for impedance curve vs frequency .

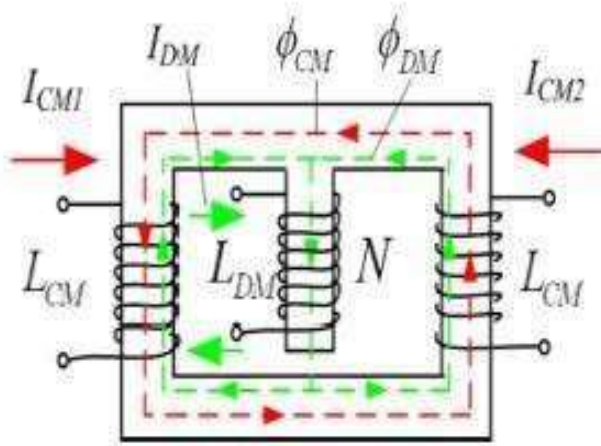

Better efficiency and material saving by integrating common mode and differential mode chokes



Operations

July 6, 2022

Operation & Infrastructure – Wound Components

MULTI SPINDLE LINE



60Mn Pcs/Annum

SINGLE SPINDLE LINE



5.5Mn Pcs/Annum

Powder Production Process



Mixing & Homogenizing
(Eirich Dry Mixer)



Pelletizing
(Pelletizer)



Pre sintering
(Rotary kiln)



Coarse Milling
(Ball Mill)



Fine Milling
(Attritor mill)



Organic Mixing
(Slurry Tank)



Spray Drying & granulation
(Spray Dryer)

Pressing Process



ROTARY

- Smaller geometry
- 0.5-24 g green core weight /pc



DORST

- Medium geometry
- 25 g - 350 g green core weight /pc.



HYDRAULIC

- Larger geometry
- 350 g to 2 kg green core weight /pc.

Sintering



Kiln 1

- Brand - **Reidhammer**
- Capacity- 10 Mn **Pcs/month**
- Year of installation 1996

Kiln 2

- Brand - **Reidhammer**
- Capacity-5 Mn **Pcs /month**
- Year of installation 2007

Kiln 3

- Brand - **Reidhammer**
- Capacity- 18 Mn **Pcs /month**
- Year of installation 2011

Kiln 4

- Brand - **Reidhammer**
- Capacity- 20 Mn **Pcs/month**
- Year of installation 2015

Kiln 5

- Brand – **CTEC**
- Capacity-27 Mn **Pcs /month**
- Year of installation 2022



Grinding



Rotary Grinder



Precision Grinder



2 Station Automatic Grinding Line



4 Station Automatic Grinding Line

Expansion Plan: Increasing Capacity of Powder Production



3600 MT / annum to 6600 MT/Annum
SOP - Q 1 2023

Salient features

- *Compact production system*
- *Precise batch composition*
- *Continuous and efficient process*
- *Improved process control*

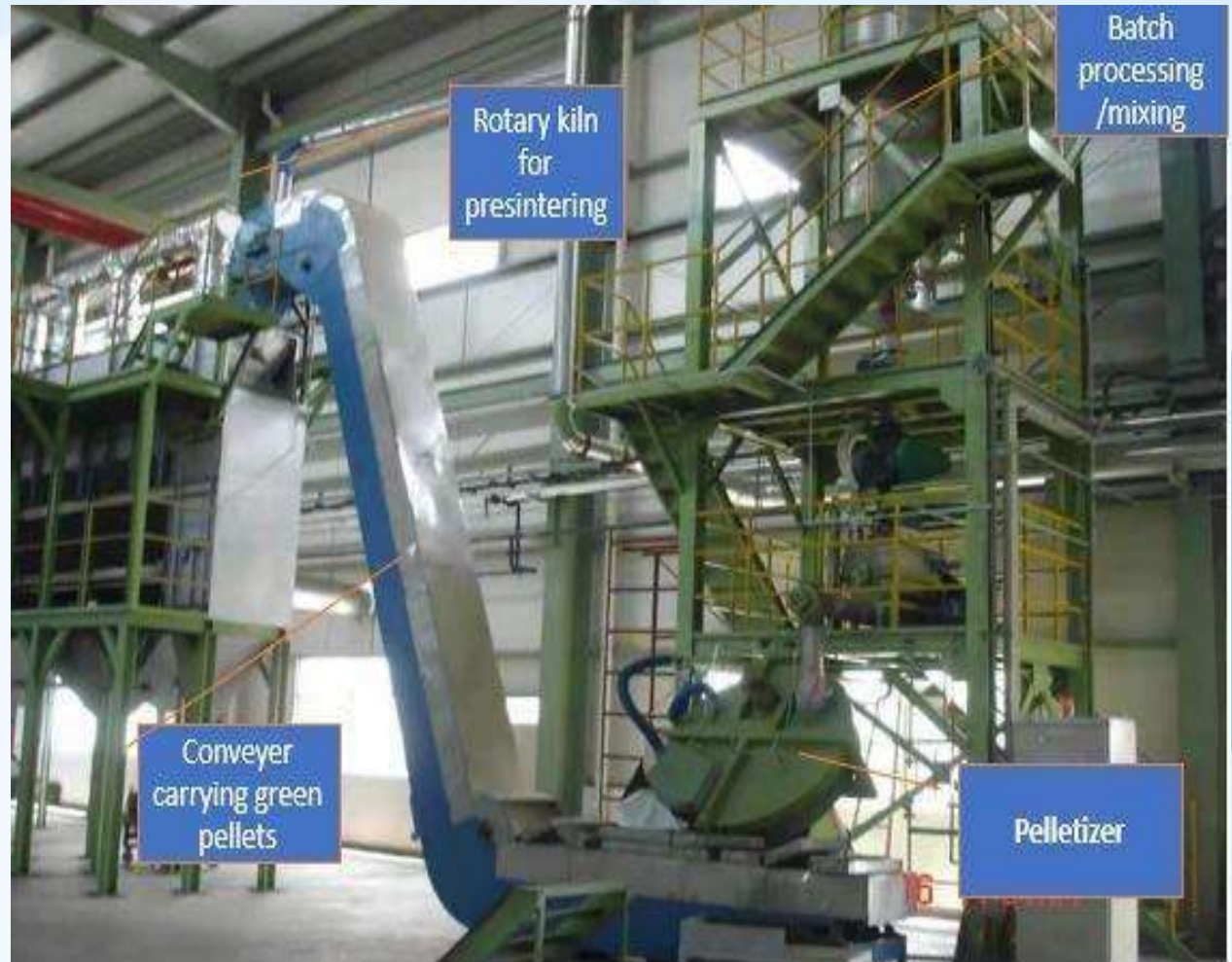

Expansion Plan: Top Hat Kiln for Sintering 10000 to 14000 μ i



Capacity of 300 MT / annum
SOP Q4 -2022

Salient features

- Sintering of high end materials with improved performance
- Precise atmospheric control
- Perfect system for
 - high permeability (μ i 10000)
 - Ultra low loss power material(80 kw/m³ at 500 KHz)
 - Ultra high saturation (B_{sat} 600 mT at 25°C)



Future Expansion Plan- FY24

State-of- The-Art Infrastructure & Building





Reach Us



NEW DELHI

Head Quarters:

517, 5th Floor, DLF Tower-A,
New District Centre, Jasola,
New Delhi – 110 025, India



HIMACHAL PRADESH

Regd. Office and Works

Post Office – Jabli
District – Solan
Himachal Pradesh – 173 209
India

Email-Id:

sales@cosmoferrites.com



Disclosure:



Certain statements in this presentation are —forward-looking statements. These statements are based on management’s current expectations and are subject to uncertainty and changes in circumstances. These statements are not guarantees of future results or occurrences. Actual results other financial condition may differ materially from those included in these statements due to a variety of factors. Any forward-looking statements made by or on behalf of Company speak only as to the date they are made, and Cosmo Group does not undertake to update forward-looking statements to reflect the impact of circumstances or events that arise after the date the forward- looking statements were made.

The background features a complex, abstract geometric pattern. It consists of various rectangular and trapezoidal shapes in shades of light blue and white, arranged in a way that creates a sense of depth and perspective, resembling a 3D architectural structure or a stylized cityscape. The shapes are layered and overlap, with some appearing to recede into the distance while others are in the foreground.

Thank You